

UniSep SM 150 magnetic separator – CE standard

TECHNICAL DATA MODEL UNISEP SM 150

Filtration capacity	150 l/min.
Tank capacity	300
Groups	Left/SX or Right/DX
Colour	RAL 7035
Voltage	400V – 50 Hz.

With neat MAX oil viscosity of 20 cSt at 40°C, flow rates shown are reduced by 50%

Con olio intero viscosità MAX 20 cSt a 40° C le portate indicate si riducono del 50%

TECHNICAL CHARACTERISTICS

- Framework in electrowelded and painted sheet metal.
- Magnetic rotor group.
- Side support by bearing flange.
- Gearmotor mod. RT 30/40 ratio 1/600 complete with multivoltage 4 poles – motor 0,18 kW for the advancement of the magnetic rotor.
- Mud scraper blade in stainless steel.
- Splash protection top covers in electrowelded and painted sheet metal

EXCLUSIONS

- Flow breaker for pump discharge (C Version)

MAGNETIC CLEANER

This system uses a permanent magnetic field filter. All metallic impurities are collected from the rotating discs and then unloaded into the collection tank.

The SM cleaner does not use vacuum filtering materials and allows the differentiated removal of the waste.

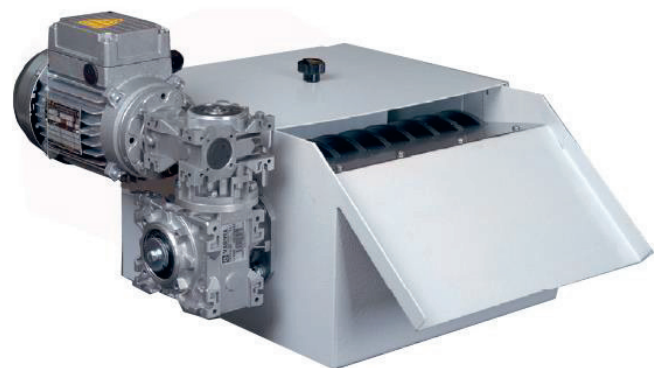

DEPURATORE MAGNETICO

Sistema che utilizza come filtro un campo magnetico permanente. Le impurità magnetiche raccolte, vengono rimosse dai dischi e scaricate nell'apposita vaschetta fanghi.

Il depuratore SM non utilizza materiali filtranti a perdere, consente perciò lo smaltimento differenziato dei rifiuti.



UniSep SM 150 magnetic separator – CE standard

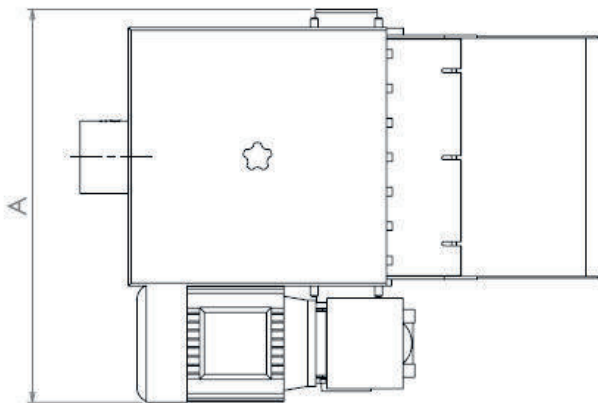
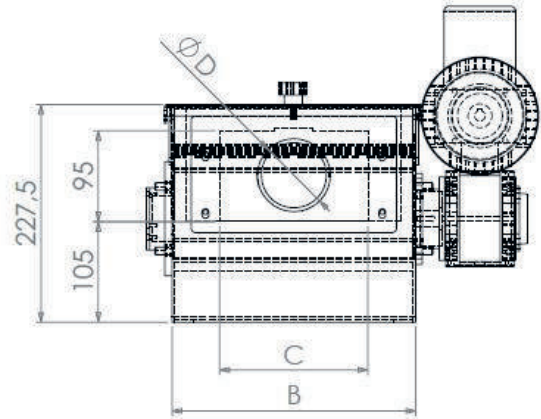
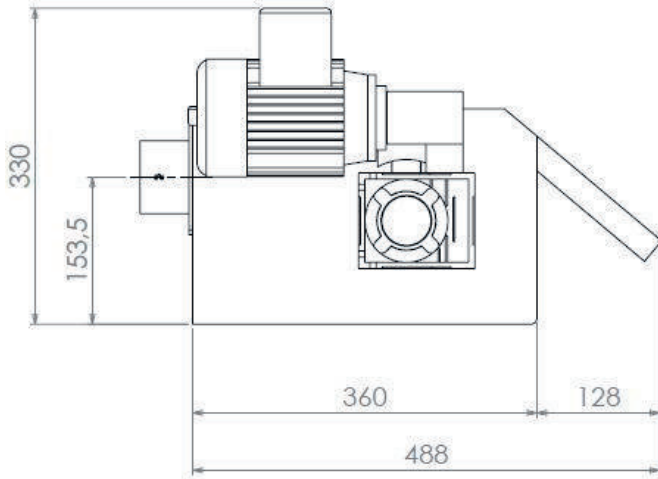

DX - RIGHT
SX - LEFT

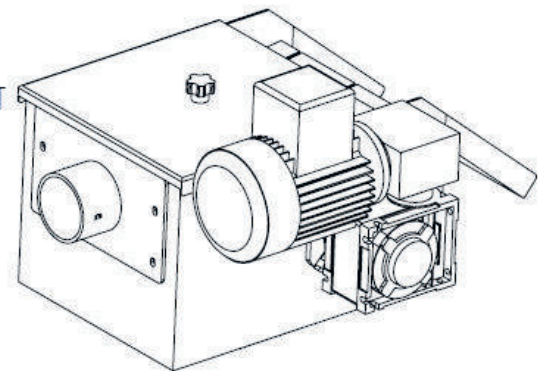

DIMENSIONS MAGNETIC SEPARATORS SM 150

Model	A	B	C	D	Capacity
SM 150	524 mm	329 mm	205 mm	3"	150 l/min

* With pure oil, capacity is reduced of 50 %
Data and characteristics are not binding and may be subject to change without notice

UNION
Your filtration partner **OILTECH**