

DX1004-T



integrate our innovative DXO Cartridge in to both new and existing systems. The Delta-Xero system can be configured up to 12 cartridges in parallel as a single unit in a compact and easily maintainable layout.

The unit can be supplied with a number of standard options to provide an effective fluid conditioning and monitoring package to suit the majority of systems. The flexibility of the unit allows tailoring to customer's specific requirements.



DX1004-T

Drive Input	Electric or Pneumatic
Connection Ports	3/8" BSP In & Out
Flow Indicator	Visual
Suggested System Volume	Up to 18,000ltrs @ 32cSt
Particulate Removal	From 0,1 µ
Weight	45 kg
Dimensions	H 916 mm x D 300 mm x L 825 mm
Material	SS316
DXO Cartridge QTY	4

Flow Rate varies depending on viscosity, pressure and temperature

Approx flow at 2.7 bar:	32 cSt	46 cSt	68 cSt	100 cSt	220 cSt	320 cSt	460 cSt
	5,0 l/min	4,0 l/min	3,2 l/min	2,4 l/min	1,6 l/min	0,8 l/min	0,4 l/min
Oil Volume	18000ltrs	14000ltrs	12000ltrs	9600ltrs	7200ltrs	3200ltrs	1600ltrs



General Arrangement

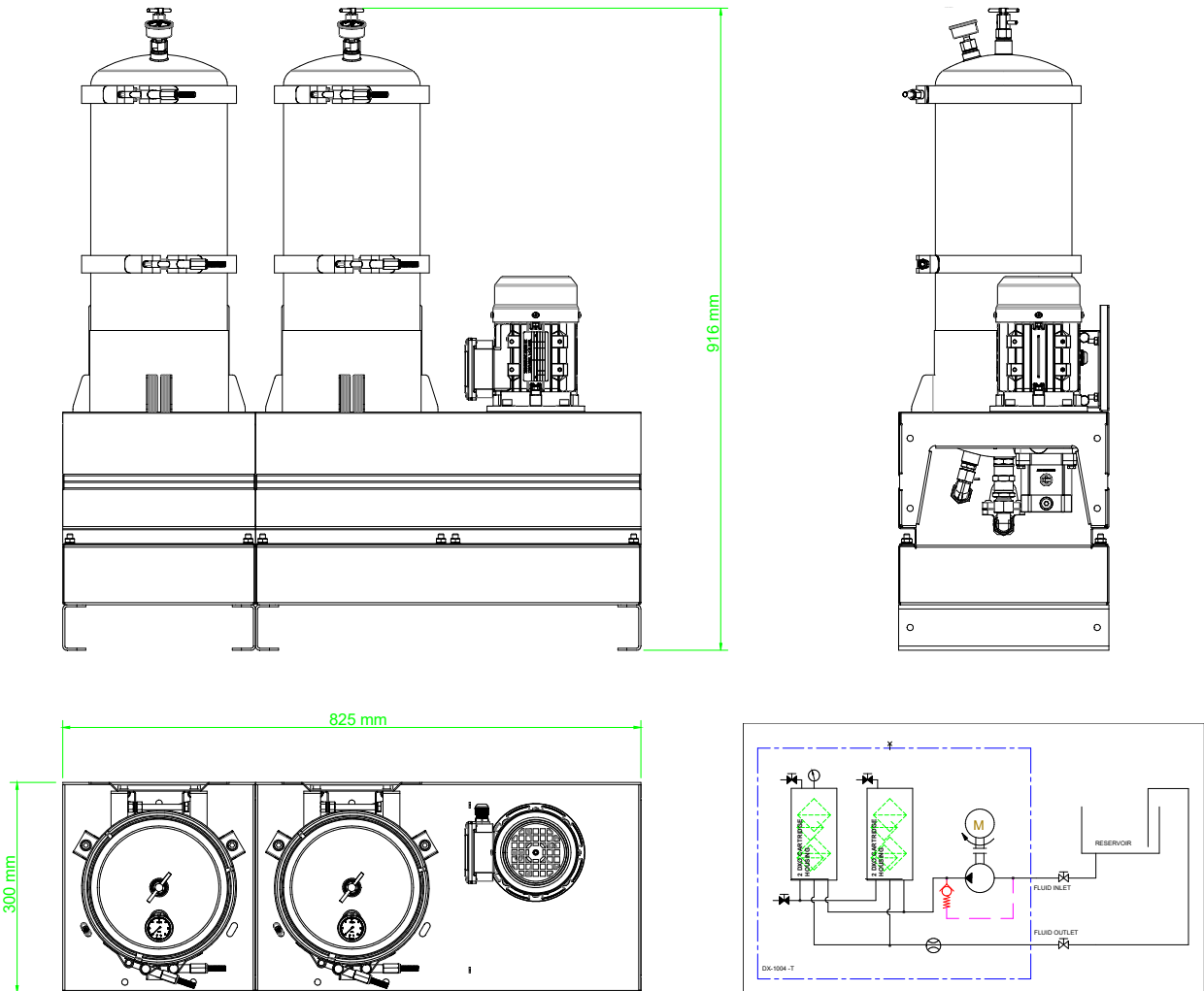

DXO Cartridge

Contamination capacity:	Up to 4.5kg per DXO
Water absorption, free and bound:	2600ml
Material insert:	PP Cellulose mix

