

# DX1002-W



integrate our innovative DXO Cartridge in to both new and existing systems. The Delta-Xero system can be configured up to 3 cartridges in parallel as a single unit in a compact and easily maintainable layout.

The unit can be supplied with a number of standard options to provide an effective fluid conditioning and monitoring package to suit the majority of systems. The flexibility of the unit allows tailoring to customer's specific requirements.



## DX1002-W

Drive Input	Electric or Pneumatic
Connection Ports	3/8" BSP In & Out
Flow Indicator	Visual
Suggested System Volume	Up to 9000l @ 32cSt
Particulate Removal	From 0.1 µ
Weight	15 kg
Measure	H 766 mm x D 261 mm x L 442 mm
Material	SS316
DXO Cartridge QTY	2

Flow Rate varies depending on viscosity, pressure and temperature

Approx flow at 2.7 bar:	32 cSt	46 cSt	68 cSt	100 cSt	220 cSt	320 cSt	460 cSt
Oil Volume	9000ltrs	7000ltrs	6000ltrs	4800ltrs	3600ltrs	1600ltrs	800ltrs



## General Arrangement

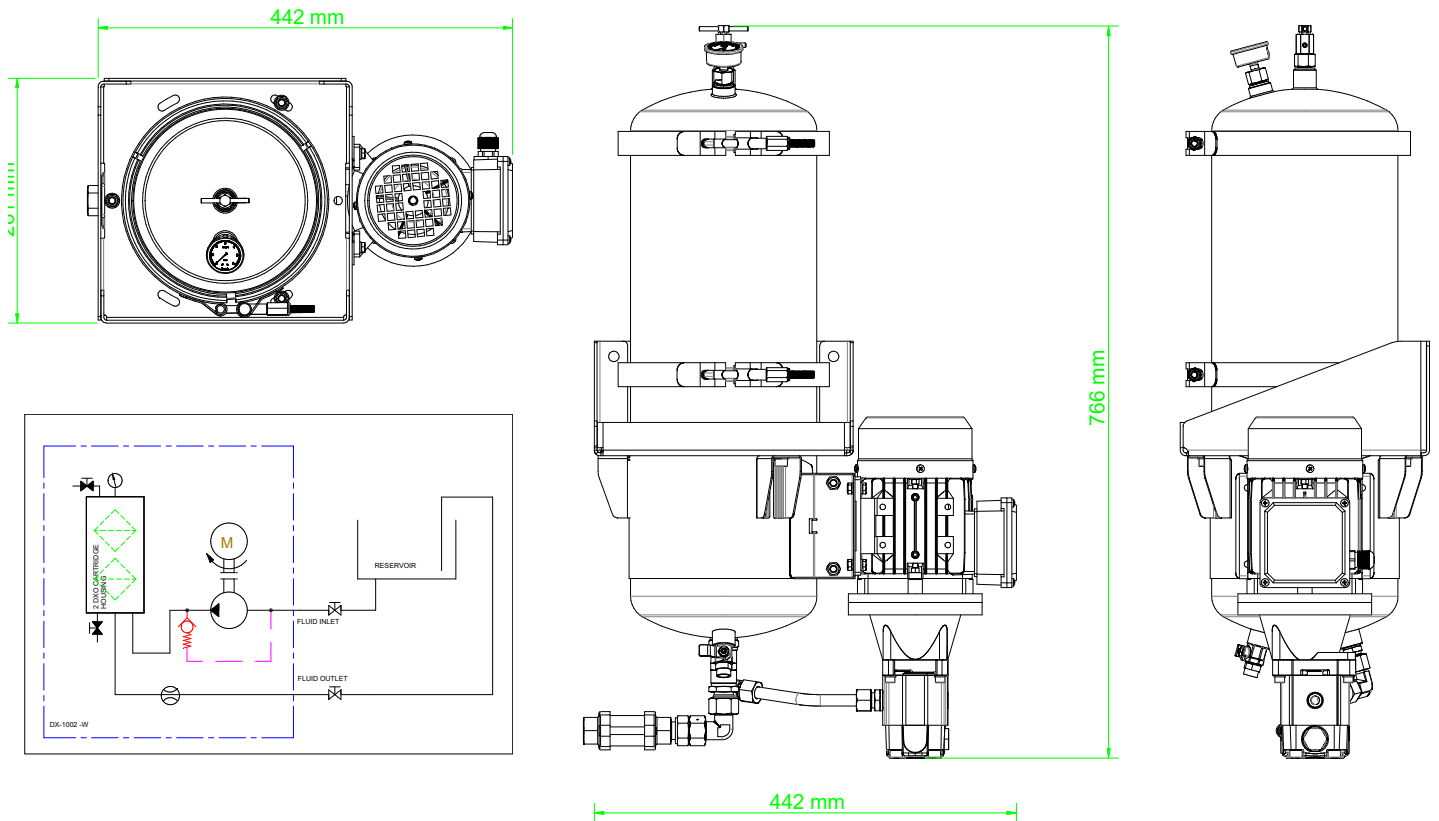

### DXO Cartridge

Contamination capacity: Up to 4.5kg per DXO

Water absorption, free and bound: 2600ml

Material insert: PP Cellulose mix

